

# CESAB P100 1.3 tonne

Powered pallet truck



## Truck Specifications



**CESAB**

## CESAB P113 Truck Specifications

CHARACTERISTICS				
1.1	Manufacturer			CESAB
1.2	Model			P113
1.3	Drive			Electric
1.4	Operator type			Pedestrian
1.5	Load capacity/rated load	Q	[kg]	1300
1.6	Load centre	c	[mm]	600
1.8	Load distance, centre of support arm wheel to face of forks (forks raised/lowered)	x	[mm]	937/990
1.9	Wheelbase (forks raised/lowered)	y	[mm]	1199/1252
WEIGHT				
2.1	Service weight including battery		[kg]	246
2.2	Axle load, with load, drive/castor/fork wheel		[kg]	535/77/943
2.3	Axle load, without load, drive/castor/fork wheel		[kg]	148/76/31
WHEELS				
3.1	Drive/castor/fork wheel			PU/PU/PU
3.2	Wheel size, front		[mm]	Ø250x60
3.3	Wheel size, rear		[mm]	Ø85x99
3.4	Additional wheels (dimensions)		[mm]	Ø100x40
3.5	Wheels, number front/rear (x=driven wheels)			2+1x/2
3.6	Track width, front	b <sub>10</sub>	[mm]	480
3.7	Track width, rear	b <sub>11</sub>	[mm]	364
DIMENSIONS				
4.4	Lift	h <sub>3</sub>	[mm]	110
	Lift height	h <sub>23</sub>	[mm]	195
4.9	Height of tiller in drive position, min./max.	h <sub>14</sub>	[mm]	858/1222
4.15	Height, fork lowered	h <sub>13</sub>	[mm]	85
4.19	Overall length	l <sub>1</sub>	[mm]	1570
4.20	Length to face of forks	l <sub>2</sub>	[mm]	420
4.21	Overall width	b <sub>1</sub>	[mm]	700
4.22	Fork dimensions	s/e/l	[mm]	76/156/1150
4.25	Width over forks	b <sub>5</sub>	[mm]	520
4.32	Ground clearance, centre of wheelbase	m <sub>2</sub>	[mm]	40
4.33	Aisle width for pallets 1000x1200 crossways (VDI 2012)	A <sub>st</sub>	[mm]	2210 <sup>2)</sup>
4.34	Aisle width for pallets 800x1200 lengthways (VDI 2012)	A <sub>st</sub>	[mm]	2062 <sup>2)</sup>
4.35	Turning radius	W <sub>a</sub>	[mm]	1410 <sup>2)</sup>
PERFORMANCE DATA				
5.1	Travel speed, with/without load		[km/h]	4,5/5,5
5.2	Lift speed, with/without load		[m/s]	0,05/0,07
5.3	Lowering speed, with/without load		[m/s]	0,05/0,04
5.8	Max. gradeability, with/without load <sup>1)</sup>		[%]	5,5/10
5.10	Service brake			Electromagnetic
ELECTRIC MOTOR				
6.1	Drive motor, rating S2 60 min		[kW]	0,7
6.2	Lift motor S3 15%		[kW]	0,8
6.4	Battery voltage/nominal capacity K <sub>s</sub>		[V/Ah]	2x 12/63
	Battery voltage/nominal capacity K <sub>s</sub> Li-ion		[V/Ah]	1x 24/50
6.5	Battery weight		[kg]	2x23
	Battery weight Li-ion		[kg]	1x6,4
6.6	Energy consumption according to VDI cycle		[kWh/h]	0,24
	Energy consumption according to EN 16796: 2016		[kWh/h]	0,20
OTHERS				
8.1	Type of drive control			Variable AC
8.4	Sound level at the driver's ear according to EN 12 053		[dB(A)]	62

Truck performance and dimensions are nominal and subject to tolerances. Specifications are subject to change without notice.

1) Measured according to company standard

2) With forks raised



CESAB P113 Dimensional Drawings

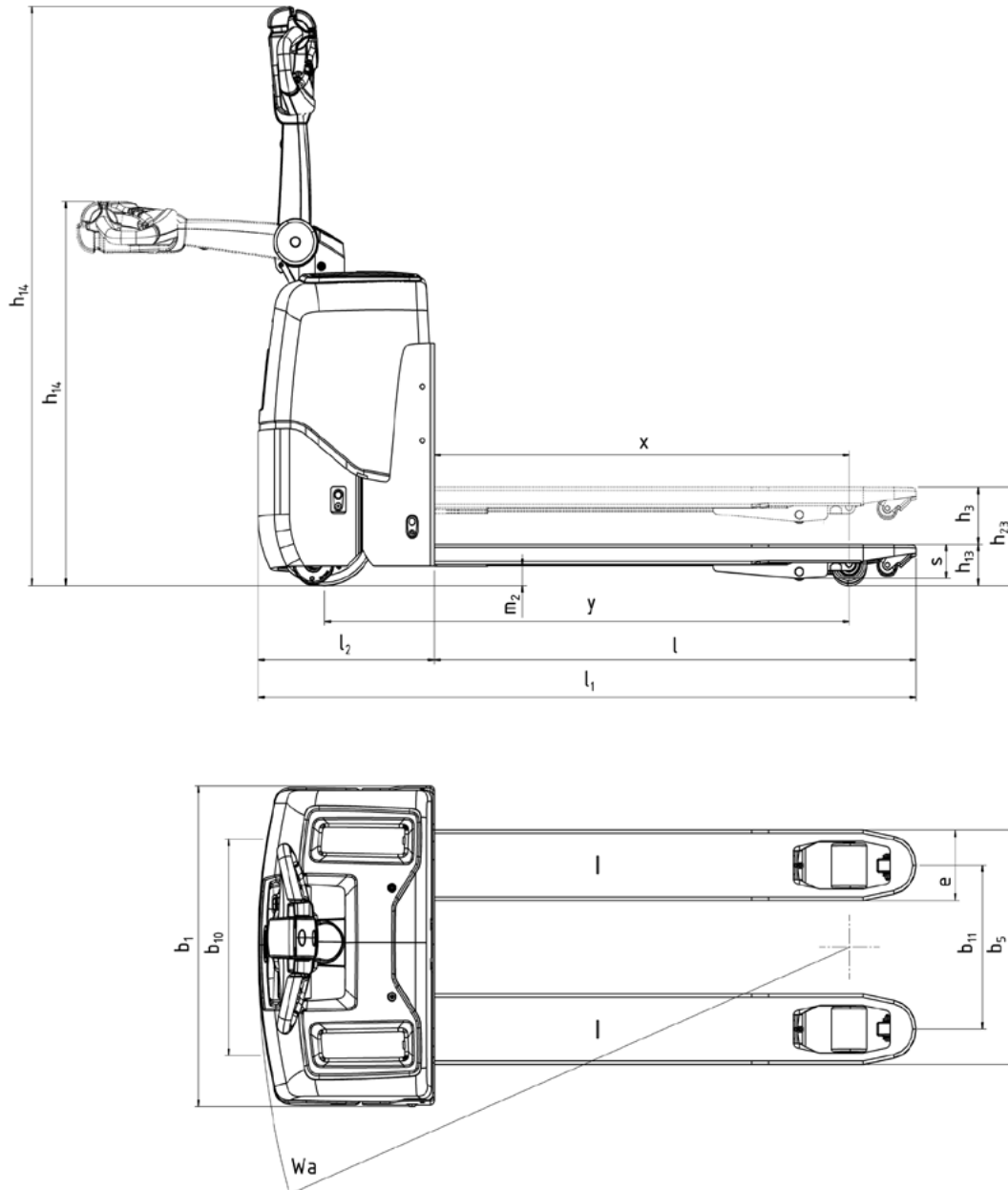

The data in this specification sheet was determined based on our standard testing conditions. Operating performance may vary depending on the actual specification and condition of the truck as well as the condition of the operating area. Availability and specifications are determined regionally and are subject to change without notice. Please consult your authorised CESAB dealership for further details. SPEC\_P100\_EN\_202311/Ucan V9 – Copyright CESAB Material Handling Europe.

